

JS series

JS/JSTH series

New Multi Purpose SCARA Robot

250/350/450/550

350TH/450TH/550TH

650TH/750TH/880TH/1000TH



JS

Series

High Reliability Acquired by Years and Years of Experience

The JS series servo SCARA robot is a multipurpose robot for various applications, developed with sophisticated technology gained through years of experience and accumulated knowledge. Janome proudly introduces the JS series to all those wanting compact, low-cost production lines, automatic and laborsaving production sites, but still needing to maintain high productivity and quality.

1 High Speed Operation

The top-level standard cycle time can be achieved by the high-powered AC servomotor and JANOME original high rigid mechanism. It ensures a higher level of productivity.

The following illustration shows the standard cycle time.



2 High Rigid Arm

A 0.04mm deflection amount (d) under a 4 kg portable weight (W) is achieved even when the Arm is fully extended. You can select heavier workpieces and wider applications.

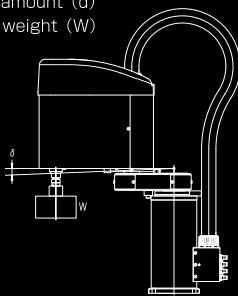

3 Wide Square Area Suitable for CP Movement

210mm × 210mm square areas $b \times b$ (Righty) and $b' \times b'$ (Lefty) are guaranteed for Model JS350.

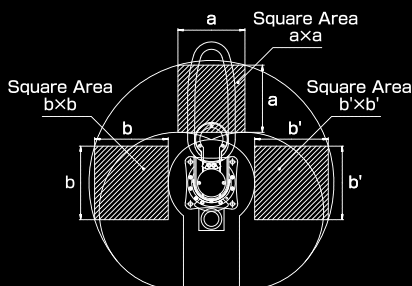

4 Stable CP* Movement by Double Shaft Mechanism

The high precision CP drive and easy Z- and R-Axes control can be achieved by the separated Z and R-Axes motors control.

* "CP" stands for "continuous path."

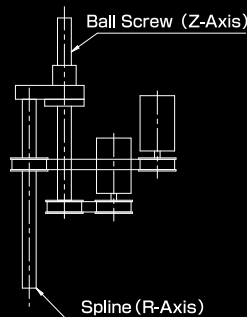

5 Single shaft allows a compact wiring layout.

All the cables for the application tools can be bundled together in the hollow Z-axis shaft; this enables simple and compact integration of application tools with the SCARA robot.



6 R-Axis Acceptable Moment of Inertia

The large R-Axis acceptable moment of inertia allows you a wider tool selection.

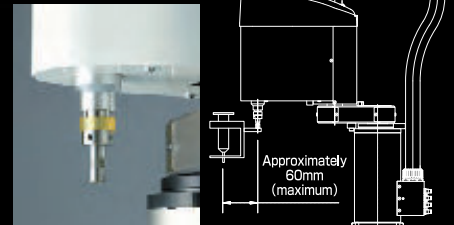

7 User Friendly Tool Piping

Fourteen signal wires and four air tubes ($\Phi 4$) come equipped with the robot as service wiring and piping. It allows you to create a compact layout.



8 Position Memory Function

The JS series can memorize the current Arm position while the power is off. You do not need to return to the work home position after rebooting the robot. Accordingly, you can reduce the work time.



Software

Work Position Input

Before entering a work position, select JOG or MDI mode simply by pressing the button on the teaching pendant. **Clearly-displayed coordinate values** allow you to correct positions easily.

Work Position Setting Screen

Program 1	P 1
R X	0 mm
R Y	4 4 0 mm
Z	0 mm
R	0deg
High	
FUNC	POS
JOG	MDI
DIRECT	



Teaching Pendant (Optional)

Application Software Examples

●Screw Tightening Software

Register **screw tightening conditions**, such as **Thread Pitch**, **Screw Length**, and **Rotate Speed**, then enter the **"screw tightening" position** and the **screw tightening condition number** for the point. The screw tightening program is now complete. You can set different tightening condition numbers to each point in order to create different screw tightening conditions in your program.

Tightening Condition Setting Screen

Tightening Condition 1	1/2
Type	Full Tightening(With Pickup)
Thread Pitch	0.5mm
Rotate Speed	600rpm
Screw Length	8mm
Check Precision	Normal
Float Amount	0.5mm
Time After Tightening	0.2sec
Feeder ESC Signal	NO
Point of Feeding	
Screw Feed Time	0.5sec
Stop After Feeding	NO
Error Restart	Next Point

●Dispensing Software

Complete a dispensing program **simply by entering work positions**, such as **"Point Dispense"**, **"Start of Line Dispense"**, **"Line Passing"**, and **"End of Line Dispense"**. You can set **"Dispense Time"** to each "Point Dispense" point. You can change **Dispense Conditions**, such as **"Device Mode"**, **"Signal Operation" type** (for dispenser), **"Wait Time"** (from Dispense ON to start shifting), **"Up Amount"** and **"Up Speed"** (at end dispensing), simply by **setting and registering data**.

Point Type Setting Screen

Program 28	P16 1/2
Point Dispense	
Start of Line Dispense	
Passing of Line Dispense	
CP Arc Point	
End of Line Dispense	
Wait Start Point	
PTP Point	
CP Start Point	
CP Passing Point	
CP Stop Point	
CP End Point	
PTP Evasion Point	

●Palletizing or Work Position Adjustment by Camera

By setting a **"Pallet Number"**, you can repeat the same operation at different points. By setting a **"Work Adjustment Number"**, you can easily adjust a position error between the standard position captured by the camera.

Point Setting Screen

Program 1	
RX+23.2 RY+312.5 Z+25 R+12	
Type	Point Dispense
Dispense Time	1.3sec
Pallet Routine Number	1
Work Adjustment Number	5
Condition Number	
Job before Moving	
Job while Moving	
Point Job Number	
PTP Condition Number	
Tool Number	
S.MARK	E.MARK
J.EXEC	P.EXEC

How to Create Application Software

You can create **original application software** for a variety of needs. For example, define a point type **"Point Dispense"** when creating the **"Dispensing Application"** software.

Register the contents of the **"point dispense" operation** in the **point type definition**.

[e.g. Start the dispenser (set #genOut1), wait for a dispense time (delay Dispense Time* 100), and then stop the dispenser (reset #genOut1).]

Register the **"Common Setting Variables Definition"** in the point type definition in order to set the **"Dispense Time"** at each point. The process is completed **simply by entering necessary items**, such as **"Variable Type"**, **"Variable Caption"**, and **"Input Unit"**.

Set **"Enumeration Type"** or **"Numeric Type"** as the **"Variable Type"**. If you select the **"Enumeration Type"**, you can select a value from the **"Selection Item Caption"** list.

Furthermore, you can set the **"Variable Caption"**, as well as variable names (identifiers), as a **caption display**.

Point Type Definition Setting Screen

Point Type Definition	
pointDispense	
Protect Mode	Public
Base Type	PTP Point
Point Type Title	
Job before Moving	
Job while Moving	
Point Job	
Job while CP Moving	
Additional Function Number	
Point Setting Variables Definition	

Point Job Setting Screen

Point Job	2/3
013	
014	Id DispenserSignalType==1
015	then
016	waitCondTime 500
017	Id #genIn1
018	timeUp
019	reset #genOut1
020	jump L1
021	endWait
022	endIf
023	delay DispenseTime*1000
024	reset #genOut1

Point Setting Variables Definition Setting Screen

Point Setting Variables Definition	
DispenseTime	
Variable Type	Numeric Type
Variable Caption	
TP Input Method	
Input Unit	sec
Decimal Figure	
Default Value	1
Maximum Value	9.99
Minimum Value	0.01

Sequencer Function

You can create simple sequencer circuits, such as a self-holding circuit, non-cumulative timer, pulse output circuit, and counter. An additional sequencer is not necessary.

Sequencer Command Setting Screen

Sequencer 1	2/3
001	Id #genIn3
002	and #genIn5
003	out #genOut1
004	mps
005	Id #mv(1)
006	or #mv(2)
007	and #genIn2
008	out #genOut2
009	out #mv(3)
010	mrtd
011	and #mv(3)
012	set #genOut3

PC Software "JR C-Points" (Optional)

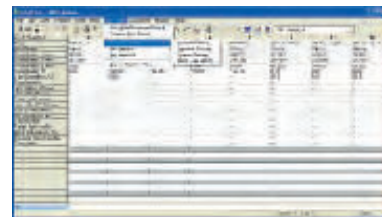

The JR C-Points is an enhanced version of JR Points, the PC software for desktop robots. Tried and tested **simple programming methods** for various applications remain. Furthermore, **additional and enhanced compile function** (robot language) and **customizing**

functions are available.

The main screen is the **plural point data setting screen**. You can create a program simply by entering necessary items, such as the **point type**, **work position**, **line speed**, **pallet number**, and **work adjustment numbers**.

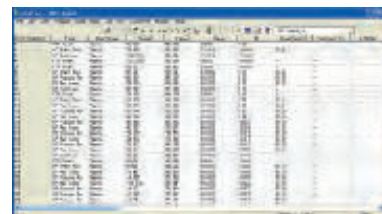

You can select a **horizontal display** or **vertical display** for point alignments. You can also check the points using a **graphic display**.

Coordinate data edited by **spreadsheets** such as Microsoft Excel can be downloaded easily using the **Copy & Paste function**. You can also convert drawings into coordinate values and download them onto a PC using **CAD data (DXF file)**.

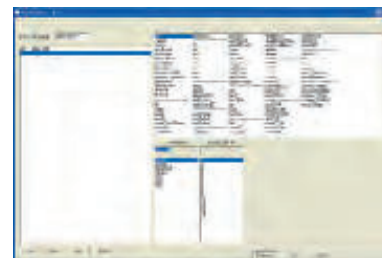

You can enter and edit a **point job** easily by selecting the desired command from the **job command list**.

Using the **compile function**, you can also read the point job data from **text files**. You can use **setting variables** to set values as teaching parameters as well as **local variables**, **global variables**, and **keep variables**. As one

of the robotic features, various **special commands**, such as the **"waitCondTime"** command to wait for an input signal (timeouts are available until receiving the input signal), are available.

Operation Box (Optional)

The operation box with start switch, program change switch, and emergency stop switch is available.



Double shaft/JS series

JS 250

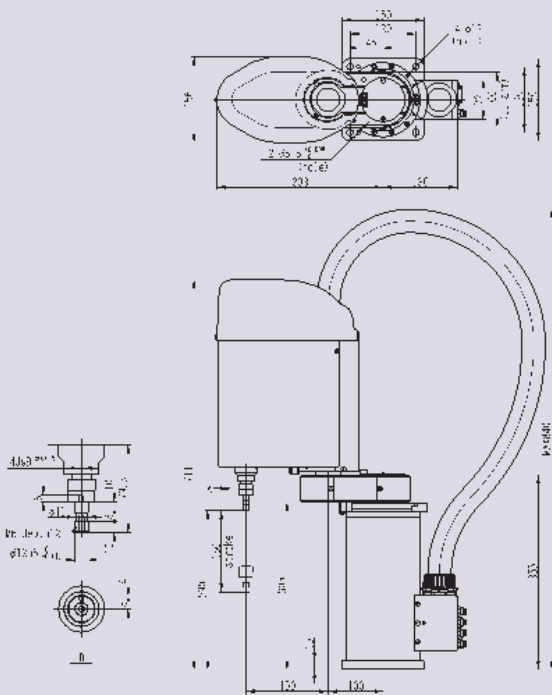

JS 350/450/550

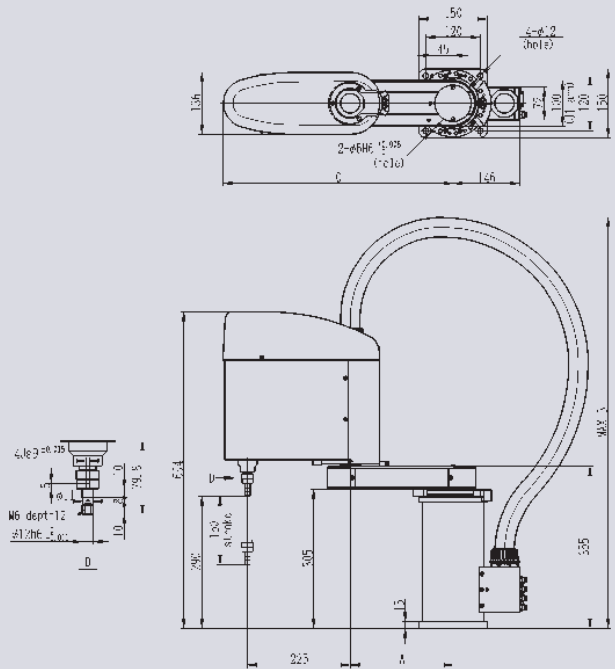

Model	A	B	C
JS350	125	840	403
JS450	225	900	503
JS550	325	900	603

Single shaft/JSTH series

JS 350TH/450TH/550TH

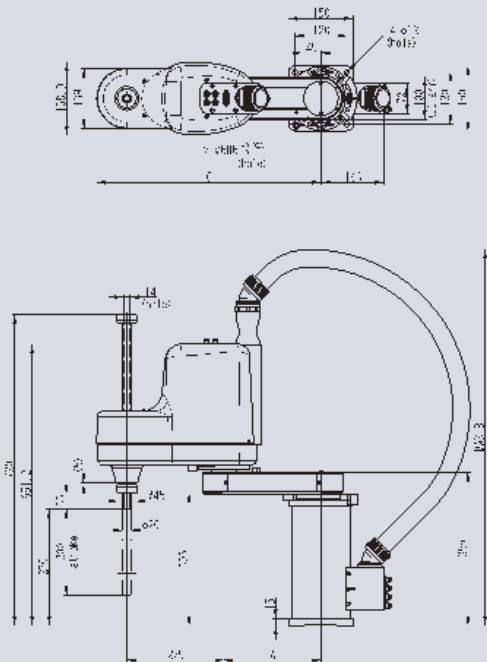

Model	A	B	C
JS350TH	125	780	419.5
JS450TH	225	870	519.5
JS550TH	325	880	619.5

JS 650TH/750TH/880TH/1000TH

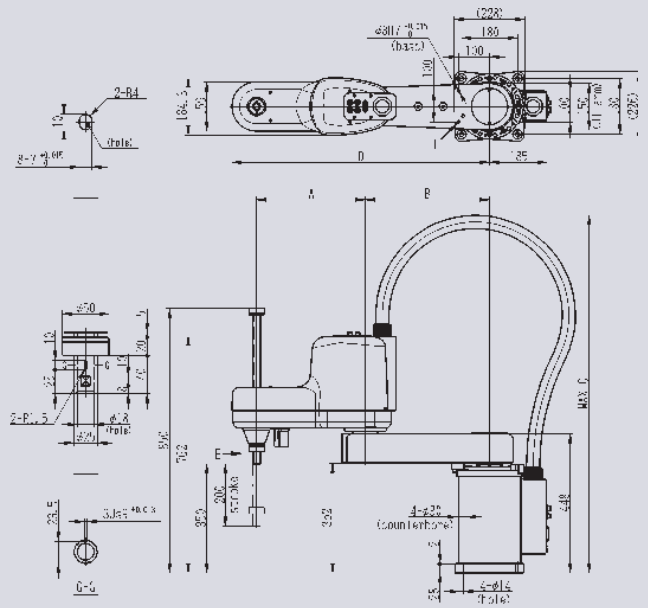

Model	A	B	C	D
JS650TH	350	300	1180	729.5
JS750TH	350	400	1150	829.5
JS880TH	480	400	1150	959.5
JS1000TH	480	520	1080	1079.5

Operation Range

**JS 250
350
450
550**

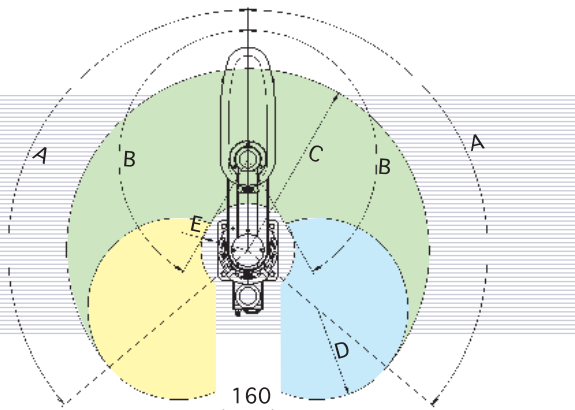

MODEL	A	B	C	D	E	Z stroke
JS250	130°	145°	R250	R150	R89	150
JS250CL		135°			R106	
JS350(CL)		150°	R350	R225	R132	
JS450(CL)		R450	R116			
JS550(CL)		R550	R172			

**JS 350TH
450TH
550TH**

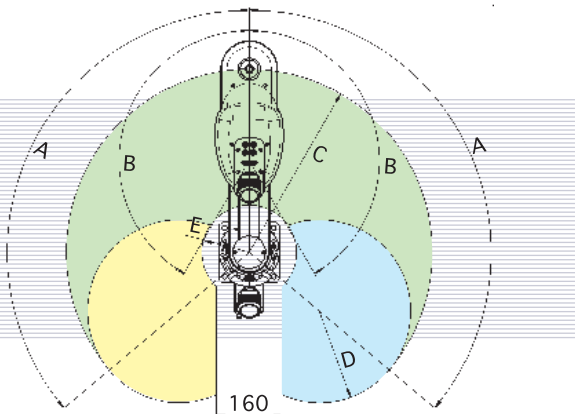

MODEL	A	B	C	D	E	Z stroke
JS350TH	130°	150°	R350	R225	R132	200
JS450TH			R450		R116	
JS550TH			R550		R172	

**JS 650TH
750TH
880TH
1000TH**

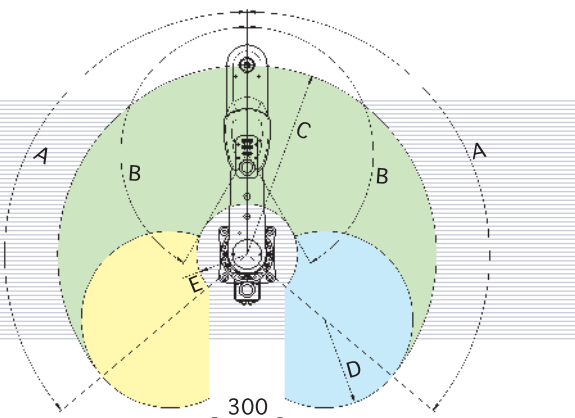

MODEL	A	B	C	D	E	Z stroke
JS650TH	130°	150°	R650	R350	R175	200
JS750TH			R750		R200	
JS880TH		160°	R880	R480	R172	
JS1000TH			R1000		R178	

Controller



External Dimensions

Full CE Specifications

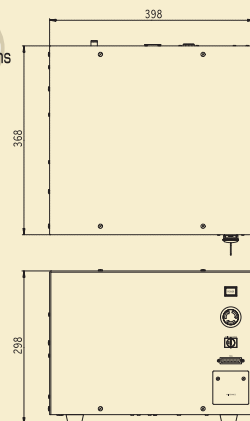

Safety Circuit Specifications

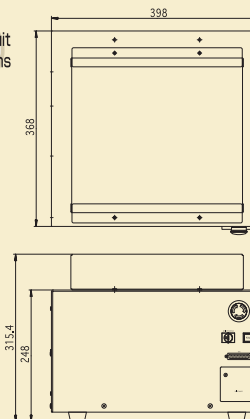

Standard Specifications

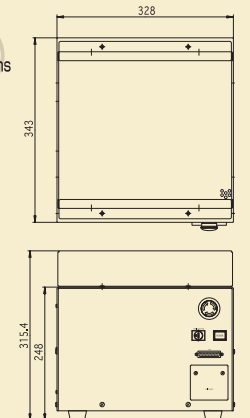

■ JS Series Specifications JS250/JS350/JS450/JS550

Model		JS250	JS350	JS450	JS550
Item					
Axis Type		4 (synchronous control)			
Arm Length	J1 Arm	100mm	125mm	225mm	325mm
	J2 Arm	150mm	225mm	225mm	225mm
	J1+J2	250mm	350mm	450mm	550mm
Operation Range	J1 Arm	±130°	±130°	±130°	±130°
	J2 Arm	±145°	±150°	±150°	±150°
	Z-Axis	150mm	150mm	150mm	150mm
	R-Axis	±360°	±360°	±360°	±360°
Maximum Portable Weight		4kg	6kg	6kg	6kg
Acceptable Moment of Inertia		0.1kg·m ²	0.1kg·m ²	0.1kg·m ²	0.1kg·m ²
Maximum Speed ¹	J1 and J2 (combined)	4,200mm/sec	6,300mm/sec	5,600mm/sec	6,200mm/sec
	Z-Axis	1,400mm/sec	1,850mm/sec	1,850mm/sec	1,850mm/sec
	R-Axis	1,750°/sec	1,900°/sec	1,900°/sec	1,900°/sec
Repeatability ²	X- and Y-Axis	±0.01mm	±0.01mm	±0.015mm	±0.015mm
	Z-Axis	±0.01mm	±0.01mm	±0.01mm	±0.01mm
	R-Axis	±0.01°	±0.01°	±0.01°	±0.01°
Standard Cycle Time ³	When carrying 1kg of workpiece	0.39sec	0.38sec	0.39sec	0.41sec
	When carrying 2kg of workpiece	-	-	-	-
Machine Weight		27kg	27kg	28kg	29kg
Control Box Weight		20kg			

■ JSTH Series Specifications JS350TH/JS450TH/JS550TH

Model		JS350TH	JS450TH	JS550TH
Item				
Axis Type		4 (synchronous control)		
Arm Length	J1 Arm	125mm	225mm	325mm
	J2 Arm	225mm	225mm	225mm
	J1+J2	350mm	450mm	550mm
Operation Range	J1 Arm	±130°	±130°	±130°
	J2 Arm	±150°	±150°	±150°
	Z-Axis	200mm	200mm	200mm / 300mm
	R-Axis	±360°	±360°	±360°
Maximum Portable Weight		6kg	6kg	6kg
Acceptable Moment of Inertia		0.1kg·m ²	0.1kg·m ²	0.1kg·m ²
Maximum Speed ¹	J1 and J2 (combined)	6,300mm/sec	5,600mm/sec	6,200mm/sec
	Z-Axis	1,800mm/sec	1,800mm/sec	1,800mm/sec
	R-Axis	1,900°/sec	1,900°/sec	1,900°/sec
Repeatability ²	X- and Y-Axis	±0.01mm	±0.015mm	±0.015mm
	Z-Axis	±0.01mm	±0.01mm	±0.01mm
	R-Axis	±0.01°	±0.01°	±0.01°
Standard Cycle Time ³	When carrying 1kg of workpiece	-	-	-
	When carrying 2kg of workpiece	0.43sec	0.45sec	0.43sec
Machine Weight		30kg	31kg	32kg
Control Box Weight		20kg		

JSTH Series Specifications JS650TH/JS750TH/JS880TH/JS1000TH

Model		JS650TH	JS750TH	JS880TH	JS1000TH
Item					
Axis Type		4 (synchronous control)			
Arm Length	J1 Arm	300mm	400mm	400mm	520mm
	J2 Arm	350mm	350mm	480mm	480mm
	J1+J2	650mm	750mm	880mm	1,000mm
Operation Range	J1 Arm	±130°	±130°	±130°	±130°
	J2 Arm	±150°	±150°	±160°	±160°
	Z-Axis	200mm	200mm	200mm	200mm / 300mm / 500mm
	R-Axis	±360°	±360°	±360°	±360°
Maximum Portable Weight		20kg	20kg	20kg	20kg
Acceptable Moment of Inertia		0.2kg·m ²	0.2kg·m ²	0.2kg·m ²	0.2kg·m ²
Maximum Speed ¹	J1 and J2 (combined)	6,700mm/sec	7,200mm/sec	6,500mm/sec	7,000mm/sec
	Z-Axis	2,000mm/sec	2,000mm/sec	2,000mm/sec	2,000mm/sec
	R-Axis	1,800°/sec	1,800°/sec	1,800°/sec	1,800°/sec
Repeatability ²	X- and Y-Axis	±0.02mm	±0.02mm	±0.025mm	±0.025mm
	Z-Axis	±0.01mm	±0.01mm	±0.01mm	±0.01mm
	R-Axis	±0.01°	±0.01°	±0.01°	±0.01°
Standard Cycle Time ³	When carrying 1kg of workpiece	-	-	-	-
	When carrying 2kg of workpiece	0.44sec	0.46sec	0.47sec	0.50sec
Machine Weight		65kg	67kg	68kg	70kg
Control Box Weight		27kg			

JS /JSTH Series Common Specifications

Drive Method	AC servomotor	
Control Method	PTP (Point to Point) control, CP (Continuous Path) control	
Interpolating Function	3-Dimensional Line and Arc Interpolation	
Position Detection	Absolute Encoder	
Teaching Method	Remote Teaching (JOG) /Manual Data Input (MDI) /Direct Teaching	
Teaching System	JANOME's original software JR C-Points: Simple and broad-use teaching system <ul style="list-style-type: none"> ●Simple: Easy teaching just by registering positions and parameters Optional system programs are available for basic operations and various applications. ●Broad-use: User-oriented programming including I/O control using point job commands 	
Teaching Pattern	<ul style="list-style-type: none"> ●Programming by teaching pendant (optional) ●Off line teaching using optional JR C-Points (PC software) via PC ●On line teaching using optional JR C-Points (PC software) via PC 	
Programming Capacity	255 programs	
Data Memory Capacity ⁴	Maximum 30,000 points	
Simple Sequencer	Maximum 1,000 steps	
External Serial Interface	RS422 1ch (for teaching pendant) RS232C 1ch (for PC: COM1) RS232C 2ch (for external devices: COM2, COM3)	
External Input/Output ⁵	I/O-SYS Input:15/Output:14 I/O-1 Input:18/Output:22 (4-relay contact) I/O-H Input:4/Output:4 (2-relay contact)	
Power Consumption	950W (JS250) 1,050W (JS350 - 550) 1,900W (JS650 - 1000)	
Power Supply	AC180 - 250V (single phase)	
Tool Wiring and Piping	14 wires for signals, 4 air pipes: Φ4 (JS250 - 550) 14 wires for signals, 4 air pipes: Φ6 (JS650 - 1000)	
Working Ambience	Ambient Temperature	0 - 40°C
	Relative Humidity	20 - 90% (non-condensing)

*1: Measured on a machine with regenerative resistors. Maximum speed cannot be achieved under the maximum portable weight setting.

*2: Repeatability was measured at a constant temperature, so absolute precision is not guaranteed.

*3: Measured on a machine with regenerative resistors. Continuous operation cannot be achieved at the maximum cycle time.

*4: The point data capacity will be reduced if the additional function data setting/point job data/sequencer data increases, due to the shared data storage area.

*5: NPN/PNP can be chosen before shipment.

● The specifications may be modified without prior notice to improve quality.

JS series

● JS 250



● JS 350



● JS 450



● JS 550



JSTH series

● JS 350TH



● JS 450TH



● JS 550TH



● JS 650TH



● JS 750TH



● JS 880TH



● JS 1000TH

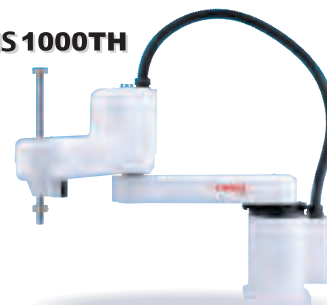

Clean Room Type Models

JS250CL / JS350CL / JS450CL / JS550CL

■ Clean Class 10 (0.3 μ m) *Specifications

- ① The special airtight structure and the vacuuming system minimize dust inside the robot.
- ② Special external conductive coating prevents static electricity.
- ③ Low dust grease is used for the Z-axis spline and ball screw; also, the Z axis is covered by a special antistatic accordion hose.
- ④ The robot's body (without the control box) can be used in both the clean room and regular environments.

■ What's Clean Class 10?

Clean Class 10 is defined by Federal Standard 209D as a particulate count that shall not exceed a total of 10 particles of a size of 0.5 μ m or greater per cubic foot of air.

Cleanliness	Class 10 (Federal Standard 209D)
Ventilator Diameter	Internal Diameter of Vent Pipe: Φ 19
Outlet flow	180NL/min (11Nm ³ /h)

*Common to the robot body and control box

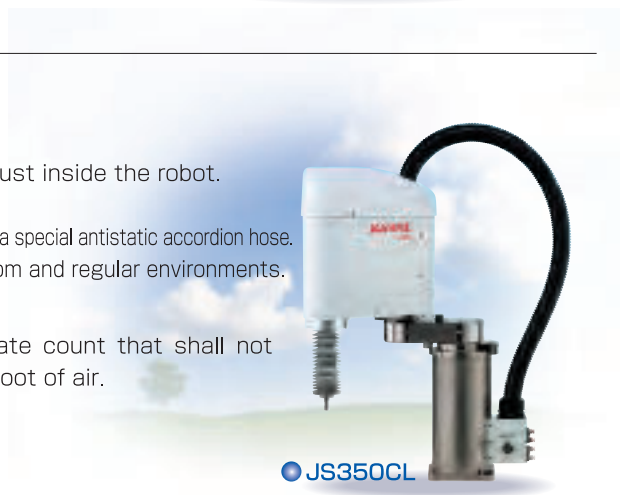

● JS350CL

Distributor

JANOME

Janome Sewing Machine Co., Ltd.

Industrial Equipment Sales Division
1463 Hazama-machi, Hachioji-shi, Tokyo 193-0941 JAPAN
Tel : +81 426 61 6301, Fax: +81 426 61 6302

U R L : <http://www.janome.co.jp/industrial.html>

E-mail : jindustry@gm.janome.co.jp

2008.11 (S)2,000